

Title Sponsor 冠名贊助機構



建行(亞洲)
CCB (Asia)
HONG KONG
WINE

&
DINE
FESTIVAL
香港美酒佳餚巡禮



AN INVITATION TO PARTICIPATE
誠邀參展 25-28.10.2018

盡享·最香港
BEST OF ALL
IT'S IN
HONG KONG



Awesome 10! Super Time!

This fall, the Hong Kong Wine & Dine Festival celebrates its 10th edition by converting the Central Harbourfront into a global fine wine and food emporium. Pairing the wines of ancient terroirs and new vineyards with products ranging from artisan cheeses and nose-to-tail organic meat, this 4-days gastronomic journey will also lead visitors to the fascinating world of sake. Foodies and wine lovers will also be drawn to unearth innovative craft beers, discover premium whiskies and have their taste buds challenged by the bold flavours and unexpected textures of dishes created by international star chefs. What's more, there will be plenty of live music, special performances and anniversary surprises to spice up this potent recipe to keep the atmosphere buzzing. Check your calendar and get ready for a superbly super time!

今年秋天，正踏入十周年的香港美酒佳餚巡禮，將再度為大眾呈獻來自新舊世界的精品佳釀、工匠芝士和當造美食。大會將設立清酒、手工啤酒和威士忌區，還有國際名廚炮製獨特的招牌菜式及挑戰味蕾的新「煮」意。非同凡響的現場音樂和豐富節目，配合十周年的特備驚喜，必為巡禮帶來多重感官享受的節日氣氛。是時候記下這個大日子。

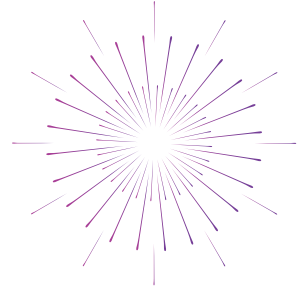

2017 Festival Snapshot

2 0 1 7 年 巡 禮 概 況



403 wine and food booths
403個美酒及美食攤位



Wineries from **20** countries and regions
來自20個國家及地區的佳釀



Attracted **141,000** wine & food lovers and industry players
吸引多達141,000名美酒佳餚愛好者及業界人士入場

Who Should Exhibit

參 展 商 概 覽

- Passionate wine merchants keen to introduce their products to new consumers
希望開拓新客源的酒品經銷商
- Restaurants and chefs looking to connect with gourmet lovers
有意接觸廣大美食愛好者的餐廳及廚師
- Innovative bar operators, beer brewers and premium whisky distillers ready to expand
新派酒吧老闆、手工啤酒及威士忌釀製商



Visitor's Profile

入 場 人 士 概 覽

- Adventurous foodies and wine fanatics on a quest for stimulating culinary experiences
追求創新及獨特美食體驗的饕客
- Government and member of the trade associations
政府及貿易商會人士
- Local and international media
本地及海外傳媒



2018 Event Preview

2018年盛宴預覽



4-7pm

下午4時至晚上7時

Opening Ceremony and
VIP & Media Preview
開幕儀式及嘉賓與傳媒預展

7:30-11:30pm

晚上7時30分至11時30分

Open to public
開放予公眾人士參加

Venue 地點

Central Harbourfront Event Space and
Tamar Park

中環海濱活動空間及添馬公園

Admission fee 入場費

\$30

(Concessionary tickets
are available
另設長者及兒童優惠)



12nn-11:30pm

中午12時至晚上11時30分

Open to public
開放予公眾人士參加

Title Sponsor 冠名贊助機構

China Construction Bank (Asia) Corporation Limited
中國建設銀行(亞洲)股份有限公司

Organiser 主辦機構

Hong Kong Tourism Board
香港旅遊發展局

Co-Organiser 協辦機構

Bordeaux International Wine and Dine Festival Organization

Festival Website 活動網頁

www.discoverhongkong.com/wineanddine



12nn-10pm

中午12時至晚上10時

Open to public
開放予公眾人士參加

Event Highlights

巡 禮 亮 點

- A stimulating business platform for merchants to discuss fresh opportunities and develop new partnerships
尋求發展商機及新伙伴的嶄新平台
- A vast wine selection representing established vineyards and up-and-coming producers from the major wine-producing regions of the world
來自世界著名和嶄露頭角酒莊的精選美酒
- A fascinating sake zone
特別為日本佳釀而設的清酒區
- A unique occasion to taste unusual craft beers and discover premium whiskies
手工啤酒及頂級威士忌品酒活動攤位
- A carnival atmosphere fuelled by live music and thrilling performances set on the central and mini stages
精彩熱鬧的舞台音樂及現場表演
- An opportunity for VIPs to join a wine tasting odyssey set in the exclusive Grand Pavilion
尊尚名酒區的非凡品酒活動體驗

Key Participation Rules

重 要 參 展 規 則

- Food and wine transactions at all booths are to made with electronic tokens only
所有攤位內的食品及酒類買賣均以電子代幣作交易
- Serving alcoholic beverages to visitors under the age of 18 is strictly prohibited
不得提供含酒精飲品予18歲以下人士
- Exhibitors shall not open any wine bottles for visitors within the festival venue
不得於活動場地為入場人士開瓶
- Food booth exhibitors must remain in compliance with the terms of the Temporary Food Factory License issued by the FEHD
食品參展商必須遵從食環署臨時食物製造牌照之條款
- Exhibitors must follow a set of detailed Rules & Regulations to be provided at a later stage
除以上守則外，所有參展商須遵從稍後提供的參展商規則

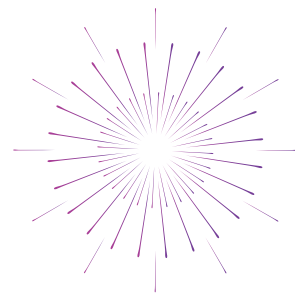

Application Process

申請程序



Product Assessment

產品評審



Information of the products for tasting in the Festival shall be submitted for assessment prior to booth confirmation to ensure quality provision of wine and food products. The selection panel will consist of professionals in the industries and representatives from HKTB, who will evaluate the products based on quality, price, uniqueness and appearance. Screening results will be announced around August. The screening results by the selection panel shall be final.

參展商於會場內提供試飲之產品資料將須於攤位確認前遞交予大會作評審，以提高活動質素。評審小組將由酒類及飲食業界專家及香港旅遊發展局代表組成，審核產品的品質、價格、獨特性與外觀。評審結果將於大概八月公佈，該裁決將為最終參展決定。

Be a Part of Our Promotion

推廣及公關宣傳

Do share with us your company's unique background or any exciting product news, which would help us both generate more talking points and media coverages.

歡迎分享有關產品及公司的獨特賣點，有助大會作重點推廣及宣傳，令您的攤位成為城中熱話！



Booth Selection Priority

挑選攤位次序

The priority below in descending order will divide applications into different product zones, with the division based on the following parameters.

攤位申請將被劃分為不同的展區組別，並按照以下條件(1為最先)安排挑選次序。



Participation Option

參展選項

Classic Booth 標準攤位

HK\$36,080

- Individual marquee for wine exhibitor in outdoor area
戶外位置獨立帳篷，可供美酒參展商租用
- The booth includes a 500W electricity socket in operation during festival opening hours
攤位包括一個500W電插座，於開放時間內為攤位供應電力
- 13% surcharge applies for successful selection of corner location
成功揀選角位位置將須繳付13%附加費

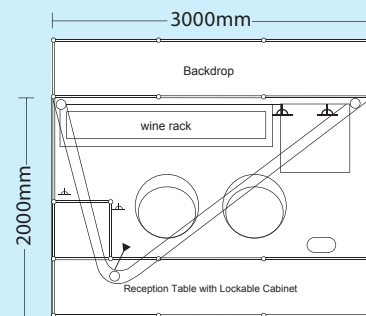
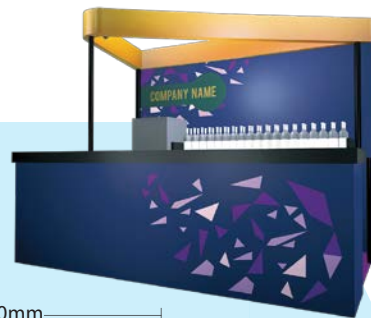
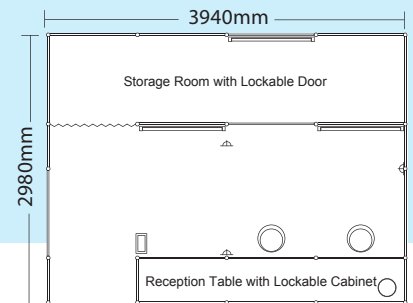

Grand Pavilion Booth 尊尚名酒區攤位

HK\$40,656

- Catered for exclusive VIP experience, showcasing fine wines valued at HK\$900 per bottle or above
尊尚名酒區為入場人士提供另一尊貴體驗，參展名酒每瓶須為價值港幣900元或以上
- The booth includes a 500W electricity socket in operation during festival opening hours and a wine chiller that works round-the-clock
攤位包括一個500W電插座，於開放時間內為攤位供應電力。另提供一個24小時運作的酒櫃

Booth layouts and furniture shown are of 2017 edition for reference only and are subject to change. The final booth specifications will be published in the Booth Vendor Manual that is to be distributed to confirmed exhibitors in August. 以上攤位設計為2017年版本，只供參考並將會有所變動。最終的攤位規格將詳列於參展商手冊。手冊將於8月向所有經確認的參展商派發。

All the above information is updated as of April 2018 but is subject to change without prior notice. The HKTBC disclaims any liability regarding the quality or fitness for purpose of third-party products or services, or for any errors or omissions. 上述資料以截至2018年4月為準，其後如有更改，恕不另行通知。第三者產品或服務之質素及適用性；或本刊物內容之誤差或遺漏，本局恕不負責。

©Copyright Hong Kong Tourism Board 2018 ©香港旅遊發展局版權所有2018年

Application Form 申請參展表格

Application deadline: 13 Jul 2018

截止報名日期: 2018年7月13日

Application method 報名方法:

Please submit online application at <https://hkwdf.discoverhongkong.com> or send the completed application form to hkwdf@baobab-tree-event.com.

請於<https://hkwdf.discoverhongkong.com>

遞交網上申請, 或以電郵方式寄出此報名表到hkwdf@baobab-tree-event.com。

Company Name 公司名稱: _____

Company Website 公司網址: _____

Contact Person 聯絡人姓名: _____ Title 職銜: _____

Contact Number 聯絡人電話: _____ Email 電郵: _____

We are an overseas merchant with business registration outside of Hong Kong 我們為海外參展商, 持有在香港以外地區註冊的商業登記

Participation Option 參展選項

1. Classic Booth (Wine) 標準攤位(酒類) X _____ (Booth quantity 攤位數量)

Whisky & Cocktail Zone
威士忌及雞尾酒區

Sake & Japanese Wines Zone
清酒及日本酒區

Craft Beer & Bubbles Zone
手工啤酒及汽酒區

Wine booth(s) not in any particular zone
分佈會場的獨立酒類攤位

2. Grand Pavilion Booth 尊尚名酒區攤位 X _____ (Booth quantity 攤位數量)



Authorized Signature with Company Chop
授權簽署及公司印章:

By signing this form, you confirm that you have read and agree the Terms & Conditions* stated below.

閣下簽署本表格, 即表示已參閱及同意下述之條款及細則*。

Date 日期: _____

* Terms & Conditions 條款及細則

Any missing information from the above will render this application form invalid. 上述表格任何缺少資料將導致此申請表不被接納。

All requests are subject to availability and the Organiser's discretion. The Organiser has the sole discretion in classifying the product sections, assigning the location of product sections as well as allocating the booth location to all exhibitors. 所有申請及展台要求會否被接納視乎供應並由主辦機構決定。主辦機構有權決定產品區的分類及位置, 及分配展位予所有參展商。

Exhibitors can only exhibit products which fall into the product section they have chosen in Participation Option. The Organiser reserves the right to immediately relocate the exhibitor or terminate its participation if the exhibitor fails to exhibit the appropriate products under its product section. 參展商於展覽會期間所展示的產品, 需符合其所選擇的產品區主題。如參展商未能展示與其參展選項主題區相符合的產品, 主辦機構有權即時重新安置其展位或終止其參展資格。

Whether an application will be accepted depends on a number of factors, including space availability. In case of over subscription of space, applicants will be placed on a waiting list and will be notified accordingly. Applicants on the waiting list will be prioritised according to the submission dates of the applications, or any rules as specified by the Organiser. 申請會否被接納取決於多種因素, 包括可供空間的情況。在超額申請使用攤位的情況下, 申請人會被列入輪候名單並據此接獲通知。在輪候名單上的申請人會按主辦機構之規定及遞交申請表的日期順序處理。

The booth configuration and facilities are subject to adjustment. The Organiser reserves the right to change the configuration and facilities without prior notice. 攤位規格及設施或有變動。主辦機構有權更改攤位規格及設施而不另行通知。

Application Enquiry 申請查詢

Exhibitor Services Manager 參展商服務經理

Baobab Tree Event 柏堡活動策劃

Ms Ruby Lee 李天慧小姐

Ms Julia Chu 朱穎琳小姐

(852) 3510 3616

✉ hkwdf@baobab-tree-event.com

Organiser 主辦機構

Hong Kong Tourism Board 香港旅遊發展局

Mr Aaron Leung 梁耀璋先生

Executive, Event Management 節目統籌主任

(852) 2807 6456 ☎ (852) 2503 6115

✉ aaron.leung@hktb.com